

APPLICATION NOTE 4322

Simplified Lithium-Ion (Li+) Battery-Charger Testing

By: Alfredo H. Saab, Applications Engineering Manager
 Shasta Thomas, Applications Engineer

Abstract: Because the charging process for Li+ batteries can take an hour or longer, testing a Li+ battery charger using its natural load (i.e., a battery) is time consuming and inconvenient. This application note presents a simple circuit for simulating the behavior of a Li+ battery, thus providing a more convenient method for testing Li+ battery chargers than using real batteries.

A similar version of this article was featured in [Maxim's Engineering Journal](#), vol. 64 (PDF, 1.99MB).

Introduction

Lithium-ion (Li+) batteries are more delicate than other battery chemistries and have little tolerance for abuse. Consequently, Li+ battery chargers are complex circuits, requiring highly accurate current and voltage settings. If these accuracy requirements are not met, the charger may fail to completely charge the battery, severely reduce battery life, or otherwise degrade battery performance.

Given the demands imposed on Li+ chargers, it is critical that charger designs be tested thoroughly and stepped through their entire operating range. However, testing a Li+ charger with its natural load (i.e., a Li+ battery) can be time consuming and impractical in laboratory and production environments. To simplify the process, this article presents a battery-emulation circuit for accelerated, realistic testing of Li+ battery chargers without actual batteries.

CC-CV Charging

The Li+ battery-charging process requires medium-accuracy constant-current (CC) charging in a first phase, transitioning to high-accuracy constant-voltage (CV) charging in a second phase.

Figure 1 illustrates the V-I characteristics of a modern CC-CV integrated circuit (the [MAX1737](#)) used for a Li+ battery charger. This type of IC is at the heart of all Li+ battery chargers in consumer products. The CC (between 2.6V and 4.2V battery voltage) and the CV (4.2V) regions are clearly shown.

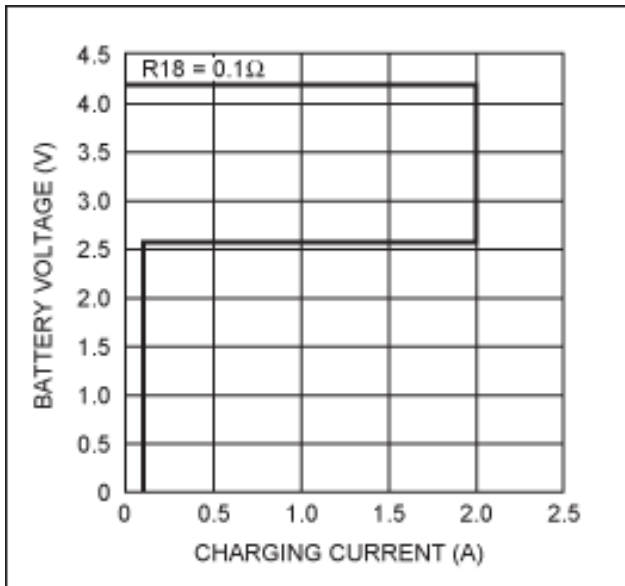

Figure 1. This V-I curve from the MAX1737 is typical for Li+ cell chargers.

The region below 2.6V requires a different charging technique. If charging is attempted on a battery discharged below 2.6V,

the charger applies a low-value ("conditioning current") charging current until the battery reaches the 2.6V level. This is a safety mechanism made necessary by the behavior of Li+ batteries when overdischarged. Forcing a fast-charge current when $V_{BATT} < 2.6V$ can cause the battery to go into an irreversible short-circuit condition.

The transition point from the CC to the CV phase has a critical tolerance of $\pm 40mV$. The reason for the narrow tolerance is that a lower CV will not allow the battery to acquire its full charge, and a higher one will reduce its useful life.

Charge-process termination involves sensing that the battery has reached its full charge and that the charger must be disconnected or shut down. This is accomplished by detecting, while in the CV phase, the point where the charge current is reduced to a fraction (usually $< 10\%$) of the so-called fast-charge or maximum charge current.

Testing Parameters for Li+ Chargers

Li+ battery-charger designs usually have two basic building blocks: a digital block (control state machine) and an analog block, composed of a well-regulated current/voltage power supply with an accurate (better than 1%) reference. A complete test of a Li+ charger product (not just the IC) is a more involved and time-consuming task than just verifying a few current or voltage values.

Testing should step the charger through its entire operating range: through the CC phase, up to the transition from CC to CV, and on to charge termination. Recall that the most realistic condition for such a test is to use the natural load for the charger: a Li+ battery. However, using a Li+ battery to test a Li+ charger is time consuming because the charging process can take an hour or more. The test time varies widely, according to whether you combine a higher-capacity battery with a slow charger, a lower-capacity battery with a fast charger, or something in between.

The charging process cannot, moreover, be accelerated beyond a limit imposed by the battery's maximum charge rate (the so-called fast-charge current) without damaging the battery. For normal batteries used in consumer products, this current is rarely specified above 1C (the current needed to fully discharge the battery in one hour). Therefore, the time required to carry the charger through the full cycle will be longer than two hours, in most cases.

If the test needs to be repeated, you must discharge the battery in full—a process only slightly shorter than charging. Or, you must have available a supply of consistently discharged batteries.

An alternative to load testing with a real battery is to test the charger using a simulated but realistic load. This simulation should verify the circuit's DC response and dynamic stability. Battery simulation, however, is difficult to implement with the standard loads used in power testing. Unlike most bench loads for power-supply testing, batteries do not behave as resistances or constant-current sinks. As noted above, testing must also step the charger through its entire operating range. The Li+ charger test circuit outlined below satisfies all of these requirements.

Choosing a Battery-Modeled Load

Let us digress to discuss two modeling approaches that should be considered, but will then be discarded.

One approach to modeling a battery load is to use a voltage source capable of current sourcing (discharge) and sinking (charge) in series with a resistor that represents the battery's internal resistance. Because Li+ batteries demand precision limits for voltage termination and charge current, all Li+ chargers today are, in effect, regulated power converters.

Moreover, because the stability of a regulated power converter (the charger) depends on dynamic properties in the attached load (the battery), you must choose a load that closely resembles the characteristics of the model. Otherwise, testing may only verify the V-I limits in the charger itself.

Using a shunt voltage regulator with a resistor in series to simulate the battery's internal resistance may be adequate, if the test is a one-time task and the simplest of battery models satisfies the test requirements. This approach also offers the advantage of being powered by the charger itself.

More rigorous testing, however, requires a more elaborate model. This model uses an internal voltage source whose value is a function of the total electrical charge supplied to the battery during the charging process.

The voltage between the terminals of a battery being charged at constant current varies continuously and with a positive slope. This behavior is caused by the progressive reduction of depolarizing ions accumulated around the battery's cathode during discharge and other chemical processes internal to the battery. As a result, the charger's operating point depends on the length of time that it has been connected to the battery, as well as the battery's past history. A load that simulates this more complex model is harder to set up using the general-purpose instruments found in most electronics labs.

When charging circuits must be tested often, or when circuit performance must be characterized in detail, a circuit that closely simulates the battery under charge is a useful bench accessory. The simulation should sweep continuously through all DC operating points possible for the charger. The circuit should also display the results so that operators can search for problems, glitches, and oscillations. If the simulator provides outputs for the battery voltage and signal, these results can be presented

directly as a scope shot.

The test can be accelerated (from hours to tens of seconds) and repeated as many times as necessary, making it much more convenient than tests with a real battery. Accelerated tests are not adequate, however, for determining the thermal effects of power stress on the charger circuits. Therefore, you may need to conduct additional tests over a longer period to accommodate thermal time constants in the charger's power and regulation circuits.

Building the Battery-Modeled Load

The circuit in **Figure 2** simulates a single-cell Li+ battery. Both the termination voltage and the fast-charge current sourced during the charger's CC phase are commanded by settings on the charger. The internal battery voltage is set at 3V when the simulator is initialized to the fully discharged condition, but that level can be raised to 4.3V for testing an overcharge condition. The 3V initialization is typical for the low-battery shutdown circuits used to terminate the discharge of Li+ batteries. This design is intended for use with standard, CC-CV type Li+ battery chargers that terminate the charge at 4.2V. The design can easily be adjusted to accommodate nonstandard levels of termination voltage and fully discharged voltage.

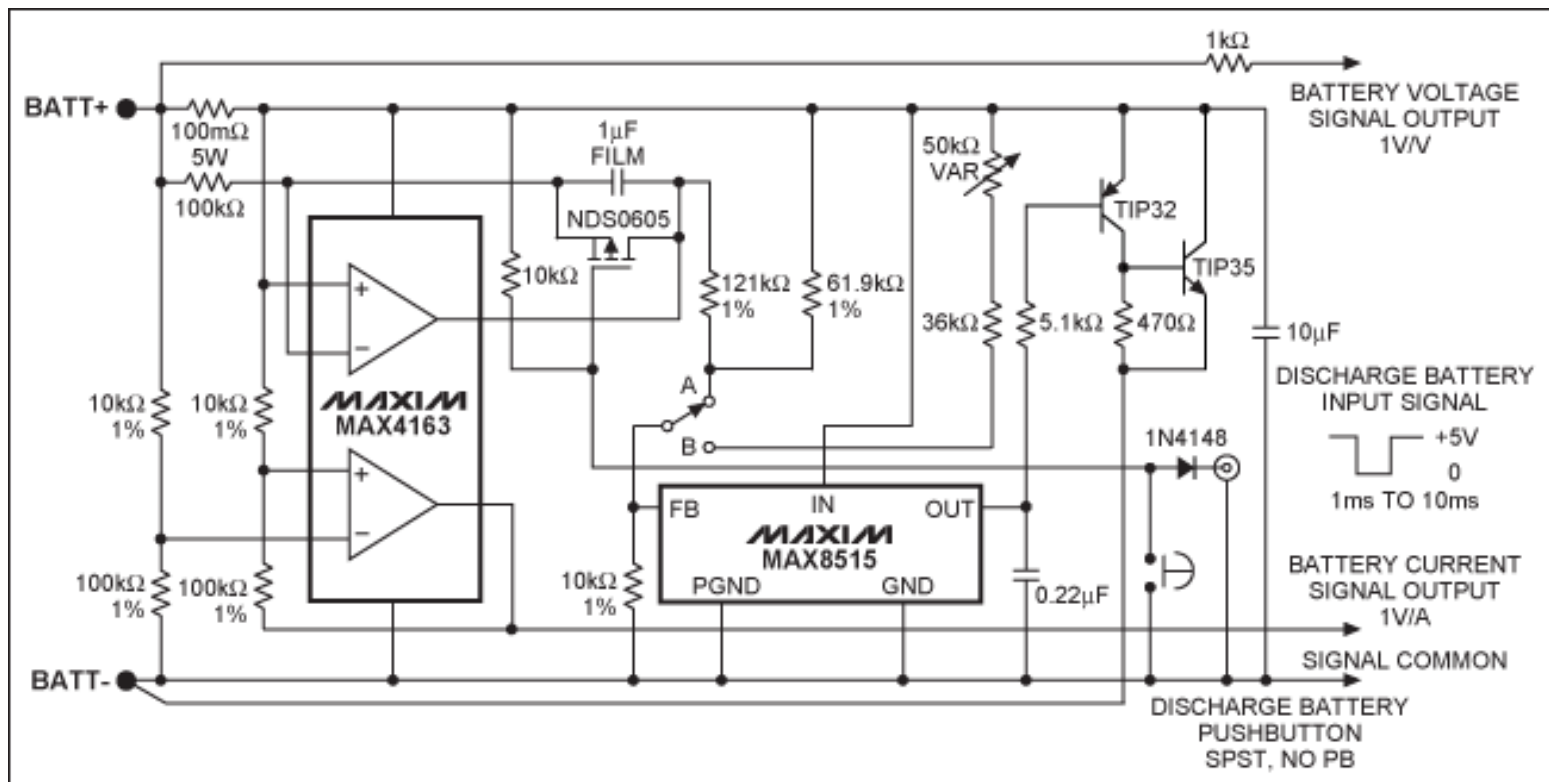

Figure 2. By simulating the behavior of a single Li+ cell under charge, this circuit lets you test Li+ battery chargers without using real batteries.

The charger under test drives the simulator with charging currents as high as 3A, subject to a limit set by dissipation in the power transistor. The battery-voltage increase simulated by the Figure 2 circuit is a function of all the charging current integrated by the circuit from the moment the simulator is set to the fully discharged state.

With the values shown and a 1A charging current, the integrating time constant allows the simulator to reach the charger's 4.2V limit in six to seven seconds. This simulation of current range, internal resistance, charge-termination voltage, and fully discharged voltage is based on the specifications of a typical Li+ cell—in this case, the Sony® US18650G3. The simulated battery voltage does not include a simulation of ambient-temperature effects.

The shunt voltage regulator is designed around a [MAX8515](#) shunt regulator and a pair of bipolar power transistors. (This regulator was selected for the accuracy of its internal voltage reference.) The high-current TIP35 transistor is attached to a heatsink capable of dissipating about 25W.

One half of the [MAX4163](#) dual operational amplifier integrates the charge current, while the other half amplifies and level shifts the current-measurement signal. The operational amplifiers' high PSRR and rail-to-rail input and output ranges simplify the circuit design for both functions. Note that the 0.100Ω current-sense resistor, in series with the positive side of the battery simulator, also serves as the battery's internal resistance.

The simulator can be reset to the fully discharged state by an external signal when operating in a system with automated test-data acquisition. Alternately, it can be reset by a pushbutton when the test setup is manually operated.

A single-pole, single-throw switch lets you choose from two modes of operation for the simulator. In position A, the switch operates as an integrating charge simulator as described. In position B, it assumes a set output voltage and sinks current as necessary for spot-testing a charger at a fixed DC operating point. For that purpose, the "set" voltage can be manually adjusted between 2.75V and 5.75V by the 50k Ω variable resistor. These set-voltage values refer to the internal sinking source. The voltage actually measured between the simulator terminals (V_{BATT}) equals the set voltage plus a drop caused by the sink current flowing in the simulator's internal resistance (the 0.100 Ω resistor). All the power necessary for operating the simulator comes from the battery charger's output.

Simulator Performance

Figure 3 shows the typical V-I waveforms obtained while simulating the charging of a Li+ battery up to 4.2V. Two test runs are shown: one with an initial fast-charge current of 1A (traces B and D), and one with a fast-charge current of 2A (traces A and C). In both cases, the CC phase continues until the termination voltage reaches 4.2V. After that point, current decays exponentially while the simulated battery voltage remains constant. The shorter time to termination for the 2A run is just what you would expect after doubling the charging current for a real battery. Notice, however, that doubling the current does not halve the total charge time; it only halves the time required to reach CV mode, as is the case with a real battery.

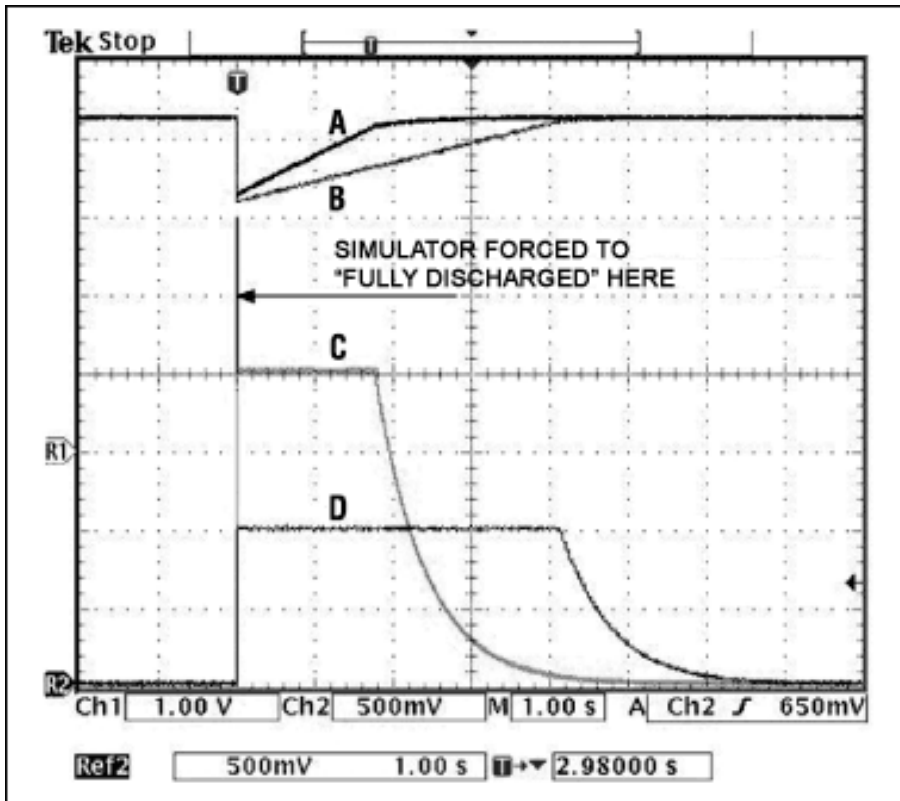

Figure 3. Taken from the Figure 2 cell-simulator circuit, these fast-charge waveforms show the behavior of a battery charger delivering 1A during the CC phase (traces B and D) and then 2A (traces A and C).

Figure 4 shows the V-I curves obtained when sinking current at two different set voltages: 3V and 4.1V. For both curves, the dynamic resistance (indicated by slope) is simply the internal resistance simulated by the 0.100 Ω resistor.

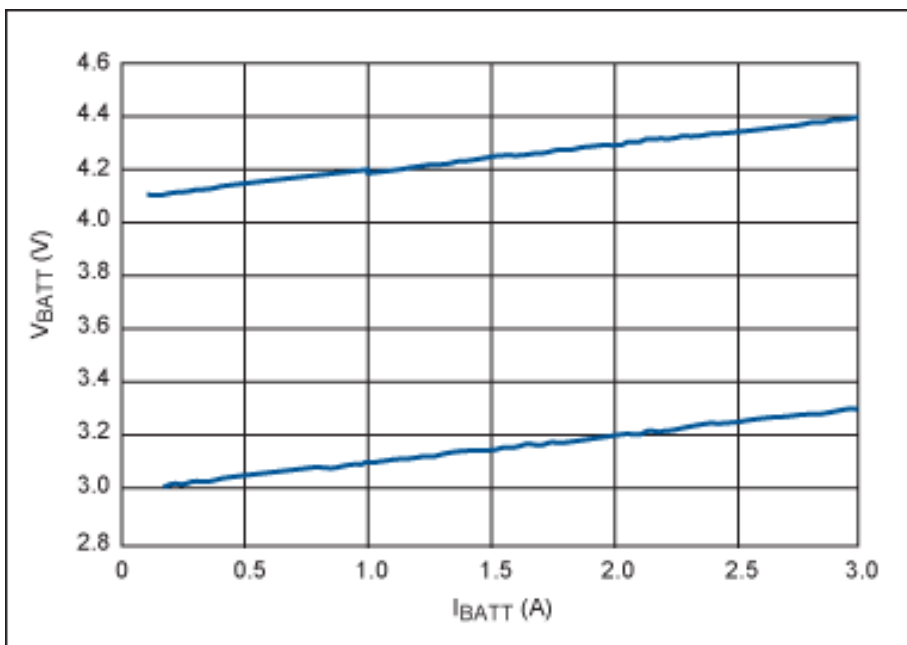

Figure 4. The slope of these plots, which represent the Figure 2 circuit sinking current at 4.1V (top trace) and 3V (bottom trace), shows the 0.1Ω internal resistance in both cases.

Summary

Because the charging process for Li+ batteries can take an hour or longer, testing a Li+ battery charger using its natural load is time consuming and frequently impractical. To speed battery-charger testing, this article presents a simple circuit for simulating the behavior of a Li+ battery. This circuit provides an efficient means of testing Li+ chargers without using real batteries.

References

- Linden, D., and Reddy, T.B., *Handbook of Batteries*, 3rd ed. (New York: McGraw-Hill, 2002).
- Crompton, T.R., *Battery Reference Book*, 3rd ed. (Boston: Newnes, 2000).
- Van Schalkwijk, W.A., and Scrosati, B., *Advances in Lithium Ion Batteries* (New York: Kluwer Academic, 2002).
- [MAX8515](#), [MAX4163](#), and [MAX1737](#) data sheets.

A similar article appeared in the May 2008 issue of *Power Electronics Technology*.

Sony is a registered trademark of Kabushiki Kaisha TA Sony Corporation.

Application note 4322: www.maxim-ic.com/an4322

More Information

For technical support: www.maxim-ic.com/support

For samples: www.maxim-ic.com/samples

Other questions and comments: www.maxim-ic.com/contact

Automatic Updates

Would you like to be automatically notified when new application notes are published in your areas of interest? [Sign up for EE-Mail™](#).

Related Parts

MAX8515: [QuickView](#) -- [Full \(PDF\) Data Sheet](#) -- [Free Samples](#)

