

Current control removes brushless DC motor commutation spikes

By Stephen Lin

Vice President, Zetex Asia

Successful removal of the excessive current and consequent back EMF present at the end of the commutation period for brushless DC motors results in improvements in efficiency, reduced component cost and lower acoustic noise. A technique of 'tail-end' current control integrated within a motor pre-driver IC provides a solution that supports existing half and full-bridge speed control circuitry.

The problem

The significance of the excessive current is illustrated in **Figure 1**. At the start of the commutation cycle, when the currents are first switched on in the coil, the rotor and stator are of the same polarity so they repel each other in the desired direction of rotation.

At this time, the current in the coil quickly rises and then levels off to a peak at approximately one quarter of the way through the commutation cycle after which point it starts to fall slightly to around 90 percent of the peak value at around three quarters of the way through the cycle. After this low, there is then a sharp rise in current flow to a level above that of the first peak.

The commutation takes place at this point; at the worst possible time where the current is at its peak value. The switching of the coil results in

a large back emf voltage across the now open circuit coil resulting in a number of undesirable effects within the motor and its electronics.

Most notable is the charge-pump effect the voltage has within the motor when a reverse protection diode is present. This is illustrated in **Figure 2** for a typical H-bridge configuration for a single-phase BLDC motor.

Current practice

A number of methods are used to compensate for these effects. One method is to over-specify the power switching devices driving the coil. This enables them to withstand the severe voltages and currents generated as a result of the back EMF. However, use of such overly robust components generally results in a more expensive solution than should be the case.

A disadvantage of over-specifying the voltage rating of power devices is that for each doubling of the voltage rating of the device, the $R_{DS(on)}$ —in the case of MOSFETs—will also double, resulting in higher power dissipation in the devices.

To help reduce the voltage 'spike,' a capacitor is included in the electronics across the power driving circuit to dampen the over-voltages present. Although this is beneficial since it saves energy in the capacitor to improve efficiency, it adds cost. The damping effect is shown in **Figure 3**.

Another method to restrict

the excessive end of commutation current flow is to advance the Hall device in conjunction with a large commutation delay time so that commutation takes place before the current reaches too high a value (as shown in **Figure 4**). However, too much advance and the motor becomes difficult to start; so there is a limit to what can be achieved.

Another method is to introduce some form of current control in the motor to 'clip' the current peak. However, this method also has an undesirable effect since it can restrict the initial current peak where most of the torque is generated.

Although any combination of the methods described above can be used, it will be apparent

that all are reactive to the effects, rather than being proactive at removing the root cause of the problem of the switching of the high currents at the end of the commutation cycle.

Tail-end current control

In the early part of the commutation cycle, when the poles of the rotor and stator are the same polarity, there is considerable work done as the two poles repel each other and are attracted to the neighbouring poles. It is in this early stage that most of the torque is generated. However, towards the end of the commutation cycle, as the opposing poles become increasingly aligned because they are attracted to each other, there is less and less torque being gen-

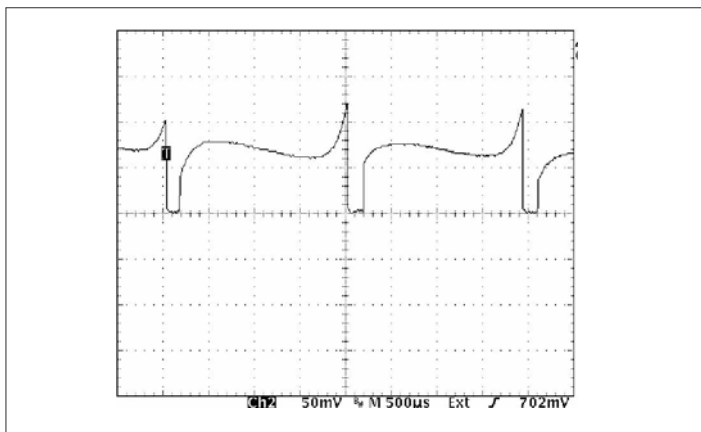

Figure 1: Typical BLDC motor supply current waveform

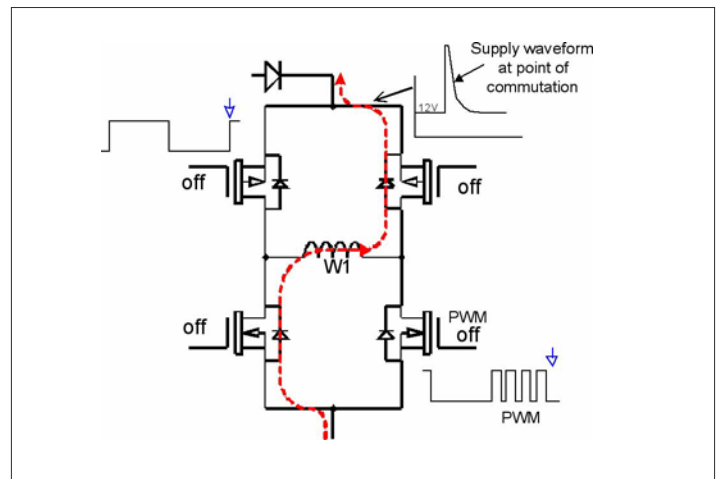

Figure 2: Attempted current path and resultant charge-pumping effect on supply

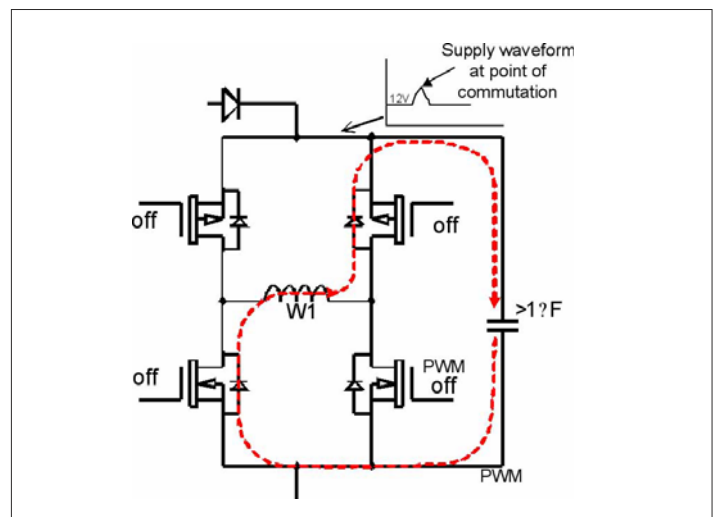

Figure 3: Removing the effects of back emf with a capacitor.

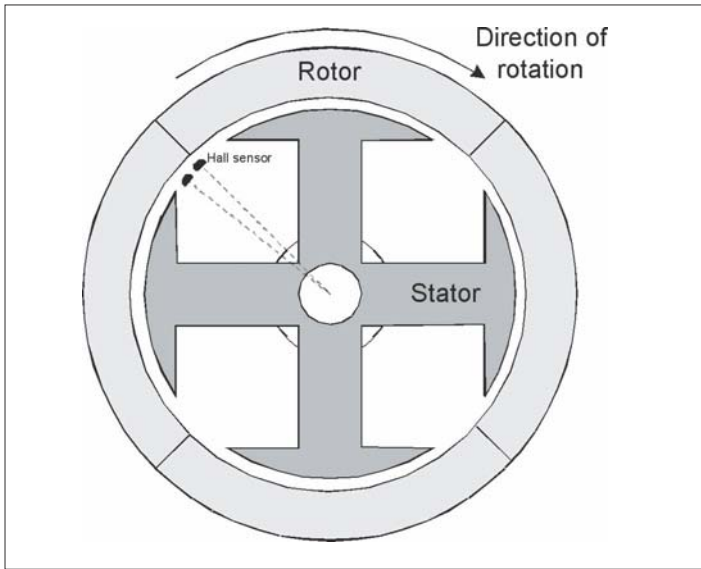

Figure 4: Topography of a 4-pole BLDC motor showing Hall device advance

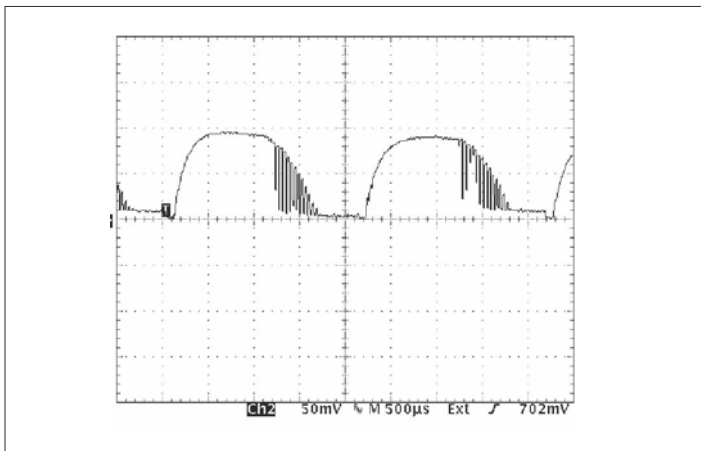

Figure 5: Revised current waveform showing the shaping introduced at the end of the commutation cycle

erated. At the same time, the current flow in the coil is becoming increasingly excessive. This excessive current needs to be kept under control to improve efficiency and to reduce the need for using over-specified components.

To control the speed of brushless DC motors, pulse width modulation (PWM) is increasingly being used to switch the coil on and off at a high frequencies. This varies the amount of energy in the coil. The PWM is also used to control the peak currents as described previously. This PWM control

circuitry is already integrated into the controller for speed control purposes and therefore lends itself as an ideal method for controlling the current flowing in the coil towards the end of the commutation cycle. The technique, therefore, is to use the PWM to slowly ramp down the current, from the low level at the 75 percent point of the commutation cycle to zero current flow by the end of the commutation.

Methodology

The PWM circuit within the motor controller is stimulated by a

	Speed (rpm)	Average Supply Current (A)
Without current control (Waveform in Figure 1)	7780	0.76
With current control (Waveform in Figure 5)	7300	0.64
Change (%)	6	16

Table 1: Results with and without Zetex tail end current control.

voltage control signal. A high voltage will provide 0 percent PWM and a low voltage 100 percent PWM. Changing between these high and low voltages provides a variable amount of PWM drive that is proportional to the input control voltage.

To apply a current reduction signal at the end of the cycle when a motor is running, we first need to know the motor speed. An integrator therefore becomes one of the first building blocks in the new system. A triangular waveform is also generated as a voltage versus commutation period signal. The integrated and triangular waveforms are then combined to provide a third signal to modulate the PWM control voltage.

Results

The resultant supply current waveform is shown in Figure 5, wherein the shaping of the current waveform can be clearly seen. This plot, when compared with that in Figure 1, quickly shows the removal of the high current 'spike' at the end of the commutation cycle. The disturbance on the supply, while not illustrated here, is also removed to zero. This evaluation was conducted on a fan running at around 7,500rpm and drawing 0.8A.

Table 1 shows the results obtained using the same fan motor, first with no modification and then again after the inclusion of current control at the end of the commutation cycle. It can be seen that the current dropped by 16 percent; however, the speed has only dropped by 6 percent, giving a

considerable improvement in the overall motor efficiency.

Tests conducted on another motor produced a current drop of 10 percent and a speed drop of 2 percent. This small loss in speed will be more than compensated for by enabling the use of lower voltage MOSFET devices with a lower $R_{DS(on)}$.

Advantages

As this technique reduces the excessive current flow in the most inefficient part of the commutation cycle, it has an immediate knock-on effect on efficiency. As described, 10 percent reduction in current consumption has been achieved with a minimal, and in other cases, zero reduction in speed. Refinement of the technique should see improvements beyond this.

The resulting ability to keep to a realistic voltage rating for the components also reduces the internal motor dissipation, which is most welcome in the cramped conditions inside a BLDC motor. And finally, since the current waveform generated by this new technique is more sinusoidal, the movement of the stator plates becomes quieter, reducing high speed commutation noise.

Zetex has already filed for patent protection for the integration of the tail-end current control technique within a dedicated motor pre-driver IC. The ZXBM1016, a motor pre-driver IC for single-phase brushless DC motors, will be the first product to incorporate the new technique and will be available for sampling soon. □