

Utilizing the RF spectrum for WiMAX

By George Wu

Director of Marketing
Technology Solutions
Fujitsu Microelectronics
America Inc.
E-mail: gwu@fma.fujitsu.com

Spectrum-regulating bodies around the world have earmarked frequency bands, both licensed and unlicensed, for broadband deployment. Semiconductor suppliers offer flexible chipsets and reference designs for WiMAX-certifiable systems to equipment vendors. These reference designs allow for a selection of RF front-ends to be combined with a highly integrated baseband processor and MAC processor SoC to accommodate a wide range of markets based on different portions of the spectrum. This article discusses the RF front-end interface to baseband (SoC), along with power considerations and future spectrum allocation.

Just as the Wi-Fi boom took off on the wings of the IEEE 802.11 standard, an emerging metropolitan area network (MAN) rocket is preparing to launch based on the IEEE 802.16 WirelessMAN standards. While 802.16x lays out the specifications for standardization and interoperability, the WiMAX Forum provides quality control and certification to ensure successfully standardized deployment.

The primary task of the WiMAX Forum is to rally a host of worldwide stakeholders—composed of chipmakers, software developers, equipment manufacturers and service providers—in support of the IEEE WirelessMAN / ETSI HyperMAN standards, and to ensure worldwide compatibility and interoperability of equipment to accelerate deployment of broadband MANs. WiMAX-certified equipment not only ensures compatibility, but also creates a broad competitive field that leads to lower cost for service providers and subscribers. IEEE 802.16 and WiMAX will propel broadband wireless access forward to accelerate affordable worldwide deployment.

However, standardization does not mean worldwide “sameness” and automatic interoperability for “all” deployed WiMAX-certified equipment. The standards define and suggest key profiles for the media access control (MAC) layer, which packs and unpacks raw data based on standard protocols to accommodate data, voice and video, and for the physical layer (PHY), which handles the air interface and modulation schemes based on subscriber needs and RF link quality. The IEEE 802.16 standard generates profiles and allows for vendor customization to meet specific requirements.

On a global scale, the actual RF interface varies by region. That is where spectrum-governing authorities, such as the U.S. Federal Communications Commission (FCC), play

creates RF-band diversity in the global deployment of WiMAX-certified wireless MANs. Service carriers and wireless Internet service providers (WISPs) within a region have band choices. Available and allocated spectrum includes various licensed and unlicensed (license-exempt) bands. A carrier may choose to use its licensed spectrum to provide service or opt to use unlicensed spectrum. Most WISPs do the latter because it is free and reduces cost to the customer subscribers.

This diversity of spectrum for the deployment of WiMAX-certified MANs results in the demand for RF-diverse base stations and subscriber stations. In **Figure 1**, a generic WiMAX subscriber station system includes a control processor, a MAC unit, a baseband processor

WiMAX-certified BWA applications include backhauling for cellular networks, wide-bandwidth backhauling for wired and WLANs, and for wireless MANs to bring BWA to homes and businesses as an alternative to DSL or cable access. However, the greatest market explosion will take place in future 802.16x versions that address portability and mobility, bringing BWA directly to the end-user. This “last-mile” market is by nature a point-to-multipoint (PMP) architecture using non-line-of-sight (NLOS) RF propagation. WiMAX-certified networks will be emerging worldwide in both licensed and unlicensed bands within this spectrum—in many cases, replacing existing proprietary pre-802.16 services.

Currently, focus has been given to frequency bands that exist in the 2-6GHz portions of the spectrum. This is where allocated bandwidths are relatively narrower than those available in the 10-66GHz range. Microwave frequencies below 10GHz are referred to as centimeter bands and those above 10GHz are millimeter bands. Millimeter bands, with their much wider allocated channel bandwidths, accommodate large data capacities. Therefore, millimeter bands are generally most suitable for very high data rate line-of-sight backhauling applications (major pipelines), while centimeter bands are well-suited for multipoint, NLOS, tributary and last-mile distribution.

The centimeter spectrum contains a significant tributary and last-mile market worldwide. IEEE 802.16d supporting fixed NLOS BWA to supplant, or supplement, DSL and cable access for last-mile service is the foundation for the first wave of WiMAX deployment. Moving forward, IEEE 802.16e will add mobility and portability to applications such as notebooks and PDAs for spectrums below the 6GHz range. Both licensed and unlicensed spectrums will be used in these deployments.

Figure 2 shows the various bands available for BWA in the

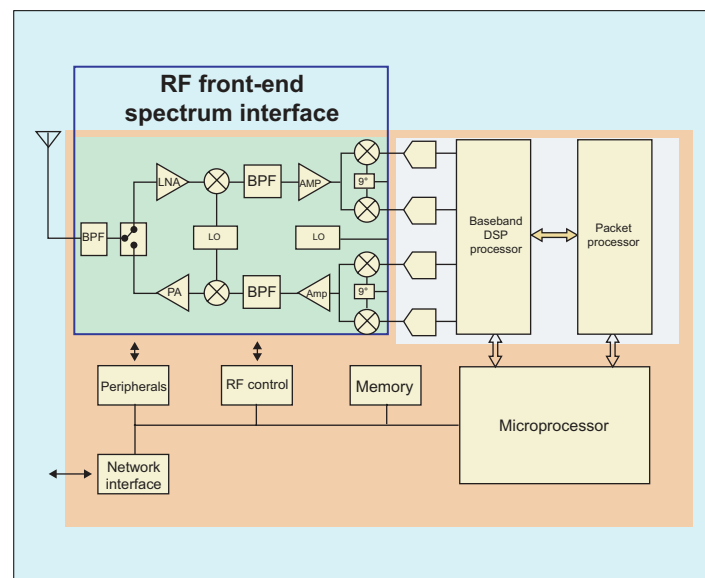

Figure 1: A generic WiMAX subscriber-station system includes a control processor, a MAC unit, a baseband processor and an analog RF front-end.

a key role in determining usable spectrum for various, and sometimes competing, services. Through these, governments make portions of spectrum that may or may not be in harmony with the rest of the world available to serve a given segment. Such is the case with the global deployment of WiMAX. Though some fairly common RF ground does exist, there is also a great deal of diversity in spectrum allocation and regulation.

It is not just regulation that

creates RF-band diversity in the global deployment of WiMAX-certified wireless MANs. Service carriers and wireless Internet service providers (WISPs) within a region have band choices. Available and allocated spectrum includes various licensed and unlicensed (license-exempt) bands. A carrier may choose to use its licensed spectrum to provide service or opt to use unlicensed spectrum. Most WISPs do the latter because it is free and reduces cost to the customer subscribers.

2-6GHz range. Note that these bands are identified as either licensed or unlicensed. Licensed bands are those that are currently “owned” by carriers that have paid for the use of these bands. Unlicensed bands are freely available for any experimental or enterprise application. IEEE 802.11a/b/g-based Wi-Fi resides in unlicensed bands and has proven to be very robust, despite competing technologies within these bands. Within each band, channel spacing is relatively narrow, thus limiting data rates as compared to the higher-frequency millimeter-band channels.

Many WISPs seek to use unlicensed bands because they are free, saving both money and time for local network deployment. This also reduces costs for the subscriber and provides

subscriber fees through the economy of scale and lower equipment costs that WiMAX certification brings.

5GHz U-NII and WRC bands

The unlicensed national information infrastructure (U-NII) bands have three major frequency bands: low and mid U-NII bands (5,150-5,350MHz) (802.11a), World Radio Conference (WRC) (5,470-5,725MHz), and upper U-NII/ISM band (5,725-5,850MHz). Wi-Fi exists in the lower and middle U-NII bands, which have demonstrated viability for BWA. Many overlapping 5GHz frequency bands earmarked for BWA growth exist around the world. The newly allocated WRC 5,470-5,725MHz band adds significant license-exempt bandwidth. Most WiMAX activities are in the upper

frequency division multiplexing (OFDM), an RF modulation technique used by both Wi-Fi and WiMAX.

2.4GHz ISM—This band is unlicensed and offers roughly 80MHz of bandwidth for BWA deployment. Wi-Fi now exists in this band and has demonstrated robust service for WLANs. Future WiMAX profiles that specify interoperable MAC and BBP requirements will bring the two services together for complementary operation that delivers wide-area mobility to the user.

MMDS—The multichannel multipoint distribution service (MMDS) spectrum includes 31 channels of 6MHz spacing in the 2,500-2,690MHz range and includes the instructional television fixed service (ITFS). This

for lower costs through the economies of scale.

Power levels and power control for both transmit and receive are extremely important for system efficiency in any WiMAX network. Levels must be actively managed to ensure solid communication and to mitigate potential interference. In addition, power levels are dynamically adjusted on a per-subscriber basis, depending on the subscriber’s profile and distance from the base station. Overall data throughput starts with adequate power levels.

WiMAX specs

As specified by the WiMAX standard, receive-level specifications are the same across the centimeter bands from 2-11GHz. The receiver must accurately decode an on-channel signal of -30dBm (1µW) maximum and tolerate a signal as strong as 0dBm (1mW) at the receiver input without damage to the front-end. In addition, the Rx should be able to provide a minimum image rejection of 60dB. The WiMAX standard specifies that the image-rejection requirement be inclusive of all image terms originating at the receiver RF and subsequent intermediate frequencies. Adherence to these requirements will ensure reliable near and far operation.

Subscriber stations that do not use subchannels (single carrier) must exhibit a minimum of 30dB range of monotonic power control. For subscriber stations that do use subchannels (OFDM), a category that will include all WiMAX-certified subscriber stations in the 2-11GHz range, the transmitter must have a dynamic power-control range of at least 50dB in no less than 1dB steps. Power-control accuracy must be within ±1.5dB over a 30dB range, or ±3dB over any range greater than 30dB.

For the base-station transmitter, output-power-level control must at least have a 10dB range. Actual transmitted power will depend on the subscriber distance, propagation characteristics, channel bandwidth and modulation scheme (BPSK, QPSK, 16QAM, 64QAM). Bipolar phase-shift keying is the least data-efficient method and is used where the subscriber station is farthest from the base sta-

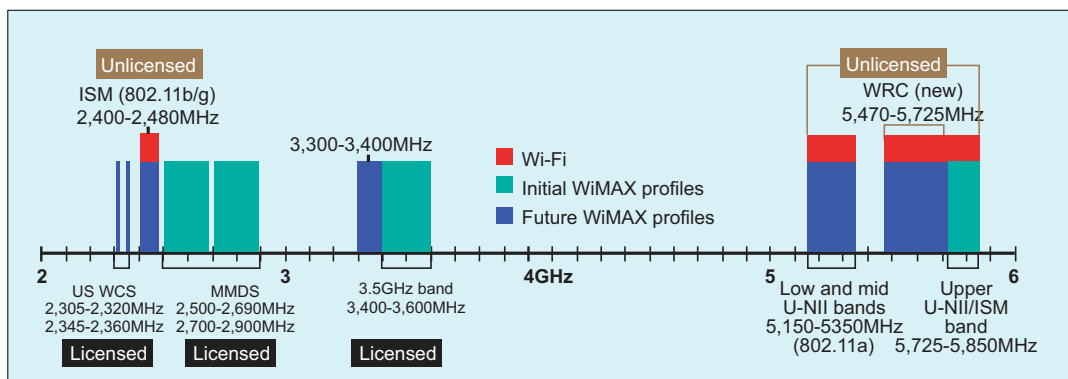

Figure 2: Licensed bands are those that are currently “owned” by carriers that have paid for the use of these bands. Unlicensed bands are freely available for any experimental or enterprise application.

a competitive alternative to DSL and cable modem services. Unlicensed spectrum is also attractive in the United States because there is not much licensed spectrum available in the 2-6GHz range. On the other hand, major carriers that have licensed spectrum can market it at a premium for “business-class” service because it is perceived to be more robust and reliable, and rides on the reputation of a major brand name.

3.5GHz band—This is a licensed spectrum that is available for BWA use in many European and Asian countries, but not in the United States. It is the most heavily allocated band, representing the largest global BWA market. Covering 300MHz of bandwidth from 3.3-3.6GHz, this band offers flexibility for large-pipeline backhauling to WAN services. With this licensed spectrum, major carriers can offer competitive sub-

U-NII 5,725-5,850MHz band because there are fewer competing services and interferences there—i.e. Wi-Fi and the outdoor power allowance are in the higher 2-4W range as compared to only 1W in the lower and middle U-NII bands. Analysts expect strong WiMAX growth in this unlicensed space.

WCS—The two wireless communications service (WCS) bands are twin 15MHz slots, 2,305-2,320MHz and 2,345-2,360MHz. The 25MHz gap between these bands is assigned to the digital audio radio service (DARS), which poses a potential interference problem caused by DARS terrestrial repeaters. Primary license holders for the WCS bands include Verizon, BellSouth, AT&T and MetriCom, along with some smaller entities. Successful deployment in these bands will require exceptional spectral efficiency such as that offered by orthogonal fre-

quency division multiplexing (OFDM), an RF modulation technique used by both Wi-Fi and WiMAX. The spectrum has been significantly under-utilized for its original instructional TV purpose, and has been allocated for BWA service in the United States by the FCC. BWA providers have gained access to this spectrum through FCC auctions and/or by leasing channels from ITFS channel holders. Sprint and Nextel are key spectrum holders here. Analysts expect significant BWA market growth in this band over the next few years.

Because of the potential for very high growth and usage, the WiMAX Forum is focusing its initial profiling and certification efforts on the MMDS, the 3.5GHz licensed bands and the unlicensed upper U-NII 5GHz band, where there is less interference, reasonable power levels and adequate bandwidth. This will ensure a high growth rate for WiMAX-certified BWA service worldwide because these bands represent the largest potential markets and allow

tion, thus requiring additional transmit power. Meanwhile, 64QAM offers high data efficiency (bits per symbol) and is used when the subscriber station is relatively close to the base station, thus requiring less transmit power.

In **Figure 1**, the interface

between the RF front-end and the SoC involves control signals to handle operation and house-keeping functions for the transmitter and receiver, along with I/Q signals interfacing with A/D and D/A data converters.

Receive data delivered by the demodulator circuit to the

SoC should be differential I/Q signals. Attenuators can be used on the receive side to handle calibration and gain control to ensure maximum bit usage and conversion efficiency of the ADCs.

Additional bands are being considered today by different regions around the world for the deployment of WiMAX and other similar broadband wireless access services.

In Japan, the 4.9-5GHz band will be used after 2007, while the 5.47-5.725GHz band is also being considered for future use. The former will require a license for base-station deployment and will support 5-, 10- and 20MHz bandwidths; the latter will support 20MHz bandwidths and will possibly not require a license.

The North American market

is indicating interest in deploying WiMAX in the 4.9GHz broad-spectrum public-safety band. There is even interest in using lower-frequency bands such as the licensed 800MHz and the unlicensed 915MHz ISM bands for WiMAX and similar types of services and deployments.

The WiMAX standard is set to bring the long-awaited spectral efficiency and throughput to meet users' needs for combined mobility, voice services and high data rates. It will enable access for more users due to its NLOS capability, lower deployment costs, wide-range capability and penetration into the mass consumer market. Needless to say, it is the clear path to broadband mobility that will form the basis of 4G. □

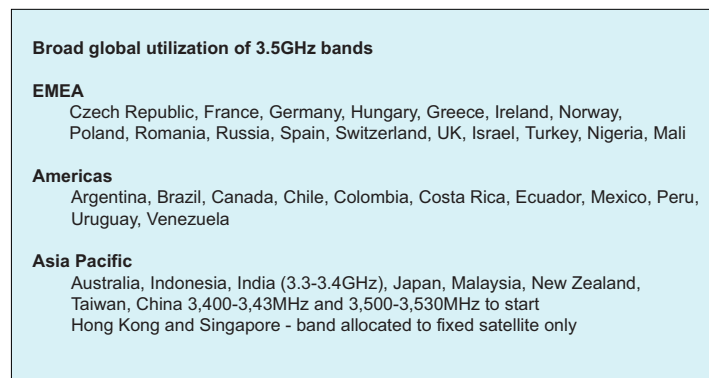

Figure 3: Covering 300MHz of bandwidth from 3.3-3.6GHz, this band offers great flexibility for large-pipeline backhauling to WAN services.