

Design and application of OLED display drivers

Ricky Ng
Design Manager
Solomon Systech Limited

Abstract

Organic light emitting diode (OLED) display has been attracting much attention in recent years for its superior performance in the aspects of contrast, thinness, lightness, power consumption, response speed and viewing angle. Meanwhile, there are challenges including brightness uniformity, parasitic capacitance and lifetime. With the introduction of high performance integrated driver ICs, OLED is becoming a viable and accessible display technology for system developers. These drivers are specifically designed, together with application techniques, to address the physical properties of OLED display panels, and have them excelling in display quality.

Introduction

The intrinsic characteristics of OLED give visual and form factor advantages over LCD and it is these advantages which have attracted over 100 companies, including major display players (eg. Samsung, Sharp, Philips, AUO, Seiko Epson, Hitachi, Sony and TMD), to invest increasing amounts of R&D effort into investigation of OLEDs and increasingly into their manufacturing. Now, real products with OLED come into the market, including cellular phones, mp3 players, digital camera, shavers and car audio. OLED technology starts its commercialization at small size display and passive displays. It is expected more and more applications would adopt OLED displays for their superior performance. Meanwhile, many companies aim at large displays such as notebook computer displays and even giant size TV displays as their ultimate goals.

Introduction to OLED

The basic OLED pixel structure consists of a stack of thin organic layers between a transparent anode and a metallic cathode. The organic layers comprise a hole-injection layer, a hole-transport layer, an emissive layer, and an electron-

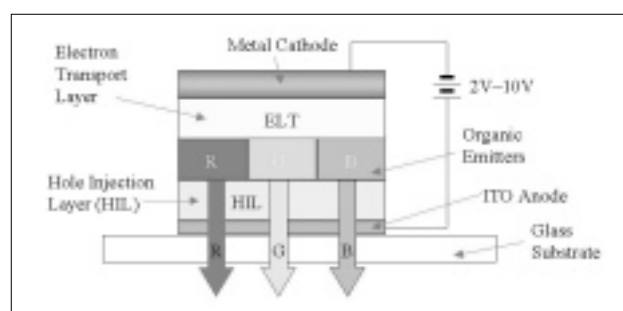

Figure 1: OLED Device Structure

transport layer. When the cell is applied with appropriate voltage, the injected positive and negative charges combine in the emissive layer to produce light. The characteristics of this basic structure appeal many engineers for its potentials on displays.

Unlike liquid crystal, field emission, or plasma displays, which require thin film processing on two glass plates, OLED can be totally fabricated on one sheet of glass or plastic. This greatly simplifies the manufacturing processes. This also makes OLED thinner than its competing display technologies. Moreover, the charge combination process causes very little time delay which results in fast response time. The major response time inhibitor is the parasitic capacitance which will be discussed later. OLED displays like LEDs and CRT, are self-emissive. Therefore no backlight is required. The viewing angle can be very large (> 160 deg), not only in horizontal direction but in all directions. With different materials OLED can produce different colors covering the visual spectrum. So, color filters are also not necessary. The absence of filters also improves light transmission efficiency and hence reduces power consumption. All these characteristics contribute to the strengths of OLED displays in brightness, thickness, structural simplicity, cost, response time and viewing angle.

Lifetime is still a major concern for OLED technology. Recent advancements in lifetime and reliability are encouraging but are still not as good as mature display technologies like CRT and LCD. The brightness of a display pixel reduces as it is turned on for a period of time. Half brightness lifetimes vary from one or two thousand hours to several tens thousands depending on material, device structure, color and brightness. This implies those most frequently used pixels would be dimmer than other pixels after certain period of usage. This is referred as differential aging. The case could be even more complicate for the fact that different colors employing different materials exhibit different half lifetime. For instance, a white display composing of RGB colors with average brightness reduction of 50% could be resulted by 70% drop in blue color, 30% drop in red color and 20% drop in green color. White balance may be difficult to be controlled.

Driving OLED Displays

OLED displays are well-known to be current-controlled display devices, contrasting to their rival LCD displays which are voltage-controlled. Nevertheless, for high-content displays, multiplexing is necessary. In such display systems, the rows are scanned one by one, by the common drivers. The segment drivers are set according to the display data. On the segment drives, voltage-drive for a short period of time before current drive is also essential to deliver high quality displays. It is usually referred as pre-charge.

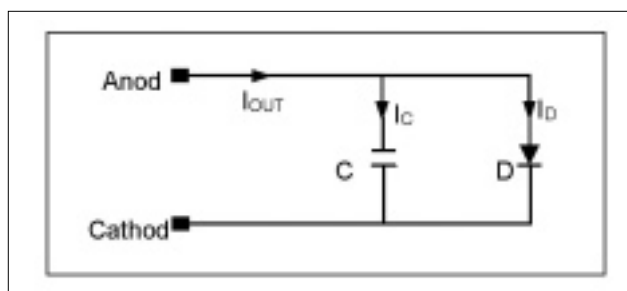

Figure 2: Electrical Model of an OLED Pixel

Each display pixel could be modeled as a diode in parallel with a capacitor. This large parasitic capacitor contributes most to the necessity of pre-charge. With a constant current source driving a pixel, the capacitor is charged-up linearly. Before the pixel voltage reaches the diode threshold voltage, there is no current flowing through the diode and the pixel is dark. Supply current is consumed only for charging the capacitor rather than light emission during this period. If the capacitance is large, and it is most likely the

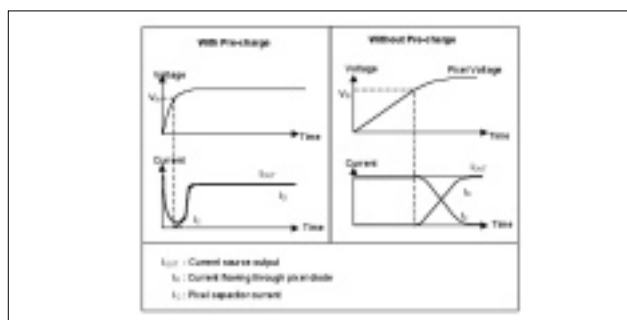

Figure 3: Driving a Pixel with and without Pre-charge

case, the pixel is off for a long time until the pixel voltage is above the threshold. Resulting from this, the pixel become dim and its brightness is difficult to be controlled.

By applying pre-charge, the pixel voltage reaches the target level quickly, and the diode current flow at the corresponding desired level. Since the charging up time is short, the variation in the charging circuit does not affect the overall brightness of the pixel.

Driver IC Design

Obviously, the current source circuits play an important role in the driver chips. One of the major circuit design challenges is to achieve high uniformity of output currents. Both circuit design and layout topology are critical to minimize the output current variation.

P-channel devices are employed in the segment drivers as current sources. A minimum VDS (drain to source voltage) voltage of 2 volts is required to ensure they operate in the saturation region, such that the current output variation versus VDS is less than 1% per voltage. It is the reason why the driver IC power supply voltage should be at least 2 volt above the panel required voltage. A row with more ON pixels draining larger current would have larger voltage loss across the connecting electrodes and hence VDS of the current sources would be lower. This VDS variation depending on the display patterns is inevitable. Therefore, the current sensitivity to VDS should be minimized.

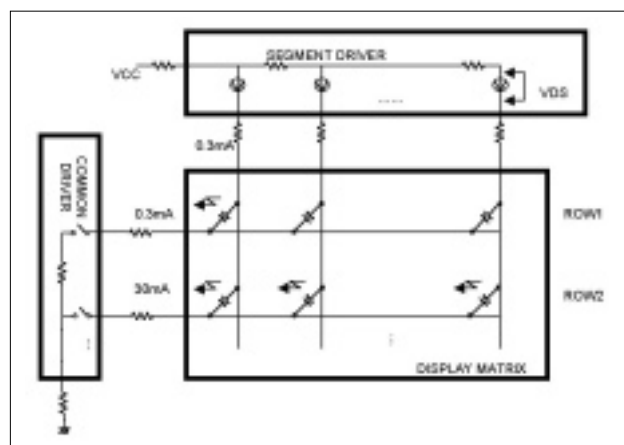

Figure 4: Display Pattern Dependent Variations

Moreover, non-uniformity of current outputs also comes from device mismatches among the current mirrors. Higher VGS (gate to source voltage) operation voltage and layout matching technique would reduce the sensitivity of current outputs to the device mismatch.

Application of OLED Drivers

The vivid OLED displays are very suitable for many portable applications such as cellular phones and mp3 players. With the introduction of integrated OLED controller driver ICs, OLED displays become accessible to these applications. Integrated drivers feature low cost and versatile functions. They embed display memory, timing controller, CPU interface, oscillator, DC/DC converter, brightness control circuits, segment and common drivers.

The first step to enable the products benefiting from the advantages of OLED is to select a suitable OLED panel.

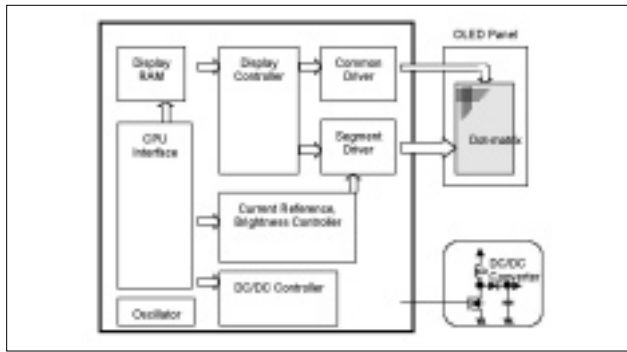

Figure 5: Functional Block Diagram of an Integrated OLED Driver

System or application engineers have to define the physical size requirement and the resolutions of the panel, and whether it is monochrome (and the color), grey scale or full color.

The next step is to select a suitable integrated OLED driver according to the following criteria:

- monochrome, gray-scale, or RGB color and the corresponding color depths
- the resolution, how many rows and columns
- the required driving voltage from the segment drivers
- the required driving current from the segment drivers
- Other special features such as area color, icon drivers, etc.

After the physical connection of the driver IC & the panel, and the hardware design, it is necessary to set the configuration of driver IC fitting the application and the panel. Most integrated driver allows programmability of the multiplex ratio. The ratio equals the number of rows of the panel. From the BVI (brightness-voltage-current) curve of the target panel at a certain multiplex ratio, according to the desired brightness, the required segment voltage and current are determined. The higher multiplex ratio, the higher voltage and current will be for the same brightness. Moreover, the internal oscillator and timing controller have to be set to obtain the desirable frame frequency which induces no flickering. Normally, a higher frame frequency would reduce display flickering but increase power consumption.

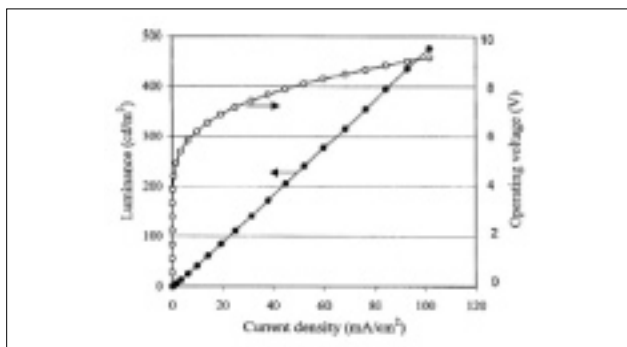

Figure 6: BVI Curve of a Pixel on an OLED panel

If the display is a gray-scale display, the gamma correction table of the driver IC has to be entered. This process aims at getting an evenly distributed grey scale of brightness perceived by human eye. To fully utilize the display row period, the brightest grey scale level should be set at

the maximum value in the gamma correction table, other levels are then determined. Turning on the display with different gray scale levels and measure the corresponding brightness. Plot a chart to depict the gray scale and make necessary adjustments accordingly.

For RGB full color displays, since each color uses different OLED materials, the BVI curves of the three colors are usually different. A good full color OLED driver should allow different segment voltage and current settings for these colors.

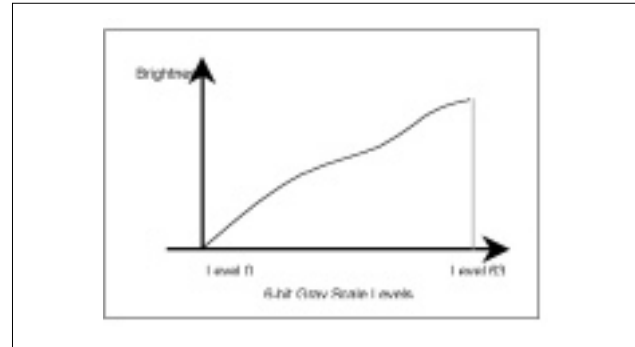

Figure 7: Gray Scale Chart

Applications Techniques

The power consumption of LCD displays is insensitive to the display patterns. It is more or less the same for different display patterns and grey scale levels. Whereas that of OLED displays is not the case. The power consumption of OLED displays increases with the brightness, the number of ON pixels, and their gray scales. Attention should be paid on the display patterns for the power conservation purpose. A text screen with a dark background certainly consumes less power than that with a white background. In addition, the overall brightness of the display could be reduced at standby mode of operation.

An effective way to reduce power consumption and lengthen operation life time is to reduce multiplex ratio at standby mode when less display contents are required.

To reduce the effect of differential aging, the application should avoid variation of utilization of different pixels. One of the effective ways is to continuously scroll the display either vertically or horizontally. Some OLED drivers have special circuits provide automatic scrolling functions, such as Solomon Systech's SSD1300, SSD1303 and SSD1325.

Conclusion and Outlook

The design and application of OLED drivers are presented. OLED as an emerging display technologies exhibit many advantages in cost structure and display quality. With the introduction different OLED drivers ICs, many applications can take the advantages and make use of it, especially portable applications with small-to-medium size displays. With proper driver IC setups and application techniques described, numerous real products are demonstrating the attractive brilliant displays in the market.

The OLED display industry is working hard on the life-time improvements and expecting continuous improvement. Meanwhile, TFT-OLED panels and the corresponding driver

ICs are being actively developed which are expected to flourish in the large display market.

References

Barry Young, "Status of OLED Manufacturing & the Search for New Applications", OLEDs 2003.

David Fyfe, "The Key Success Factors for the Adoption of PLED as a Display Technology", OLEDs 2003.

A. Sempel and R. Los, "Current Driver System IC for Segmented Polymer Light Emitting Display", SID 00 Digest, p.139.

About the author

Ricky C.Y. Ng
Solomon Systech Limited
6/F, No.3 Science Park East Avenue,
Hong Kong Science Park, Pak Shek Kok, New Territories,
Hong Kong
Phone: (+852) 2207 1695
Fax: (+852) 2267 0800
E-mail: rickyng@solomon-systech.com
Website: www.solomon-systech.com

Ricky C.Y. Ng received his B.Eng. degree in Electrical & Electronic Engineering from the University of Hong Kong, and MSc degree in Electronic Engineering from the Hong Kong Polytechnic University. Mr. Ng's career has focused on display semiconductors, including LCD drivers, LED drivers, OLED drivers, FED drivers, graphic controllers and monitor MCU since 1992. He has been serving in various positions as product engineer, test engineer, product manager and design engineer in Motorola Semiconductor Products Sector and Solomon Systech Limited. Mr. Ng is now leading the OLED/LED driver design team in Solomon Systech Limited.