



FLASH370i™ 5V to 12V DC-DC Converter Solutions

Introduction

This application note provides various solutions for the 12V supervoltage requirement for our flash-based In-System Reprogrammable CPLDs in designs that do not already include a source for 12V.

Applications for ISR

Cypress offers a line of In-System Reprogrammable (ISR™) CPLDs. This family of devices, called FLASH370i™, may be reprogrammed many times in your system, after the component has been soldered onto your printed circuit board. This provides tremendous flexibility in a number of different applications.

Typically, ISR capability is used to *simplify the manufacturing process*. The CPLDs may be programmed after the board is completely populated. This eliminates the extra manufacturing step required for programming, as well as the associated physical handling, and temporary routing of programmed parts as sub-assemblies. ISR capability is also commonly used during *development*. This feature allows Engineering to make changes without the inconvenience and expense of socketing and removing parts for reprogramming each iteration. The third use is *in-factory configuration*. For some products, a generic board may be designed, and configured to various options before it is shipped. With ISR, the hardware may be completed and stocked as a single generic assembly and programmed as a specific product option just before it is shipped. Or it may be programmed with *self-test* algorithms, and reprogrammed with final product algorithms after completing preliminary testing. The fourth use of ISR is *field upgradability*. Circuits may be reprogrammed in the field to implement upgrades or fixes. The fifth use of ISR is *system reconfigurability*. A system may have multiple functions stored in firmware, that may be reprogrammed into the system logic in the field, or even on-the-fly by the system processor. This is a feature formerly associated only with RAM based technology. But FLASH370i offers both non-volatility, and system reconfigurability.

What About Vpp?

The FLASH370i family uses flash-based technology, which implies the use of a programming supervoltage, Vpp. Vpp for FLASH370i is 12V±5%. In most applications, this voltage is supplied by external programming equipment. In the case of *system reconfigurability* (the fifth application of ISR discussed above), this voltage must be supplied locally, by the system. Where do you get that voltage if your system does not include 12V? This application note provides a number of solutions to that problem, and rates those solutions according to various criteria.

If your system uses multiple FLASH370i components, they may be designed with individual programming ports, or daisy-chained. Daisy-chained components may either be programmed individually, or in parallel groups of any quantity.

When a single FLASH370i component is in a programming cycle, the load current on Vpp (Ipp) is 40 mA maximum. Ipp for devices that are not in a programming cycle is less than 1.0 mA. If you are programming devices in parallel, Ipp is additive, i.e., a group of three devices programmed in parallel requires approximately 120 mA.

Design Criteria

For this application note, solutions were chosen optimized for an output current of 50 to 100 mA, where there was a choice. This was intended to provide some margin for programming a single device, and immediate capacity for programming at least two devices. For all solutions, Iomax exceeds 100 mA, and most manufacturers offer migration paths for even greater current requirements. All final designs include an inhibit feature, that allows the system to turn the converter off when devices are not being programmed. Surface mount components and pricing were used wherever possible, and all solutions were prototyped and verified.

Three Categories of Solutions

The solutions fall into three categories. There are two manufacturers who make monolithic solutions apparently designed for the flash programming niche. There are two companies that offer monolithic solutions for more generic applications. The third category is the hybrid approach. Maxim and Linear Tech are in the first category. Micrel and Semtech fall into the second category. Endicott Research Group, and Power Trends are in the third category.

The hybrid module approach, while potentially a “single-component” solution, is typically considerably more expensive, and none of the hybrid modules evaluated for this application note had an “inhibit” feature (to be used to turn the converter off when the CPLDs were not being programmed). In each case, the manufacturer’s engineering and applications departments aided in designing this additional feature. As a result, single-component solutions grew to multiple components. If your application requires 12V elsewhere, these parts are easy and quick to use. But the additional components for the inhibit feature make them much less cost and space efficient for the purposes of this application note. Height would also be a problem if your system has that physical limitation. For these reasons, design details for the hybrid solutions were not included in this application note.

Table 1 provides the key component manufacturer and part number, the total part count required by each solution, Iomax for each, the key component package type, the circuit efficiency at 50 mA and 100 mA, the total solution cost based on 100 piece quantities, and the total solution cost based on 10,000 piece quantities.

Table 1. Solution Comparison Chart

Mfg	Part #	Parts	I _{omax}	Pkg	50 mA Eff	100 mA Eff	Cost/100	Cost/10K
Linear Tech	LT1013	6	150 mA	SO-8	88%	88%	\$4.70	\$3.87
Maxim	MAX761	6	150 mA	SO-8	87%	87%	\$4.54	\$3.65
Micrel	MIC3172	10	140 mA	SO-8	>70%	>70%	\$4.89	\$4.03
Semtech	SC1628	13	150 mA	SO-8	88%	89%	\$9.54	\$7.60

Schematics and BOMs

The following are schematics and bill of materials for each solution.

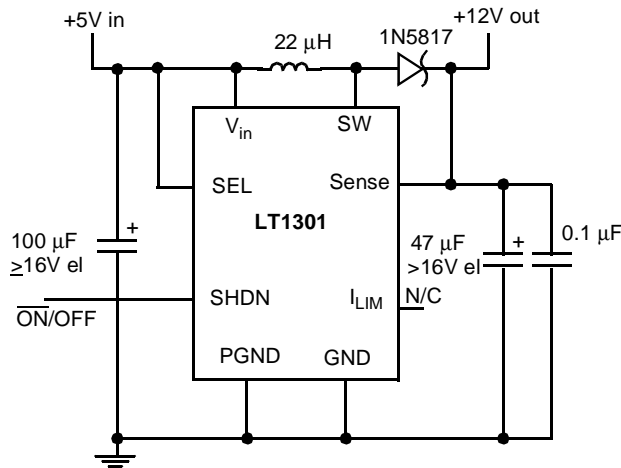
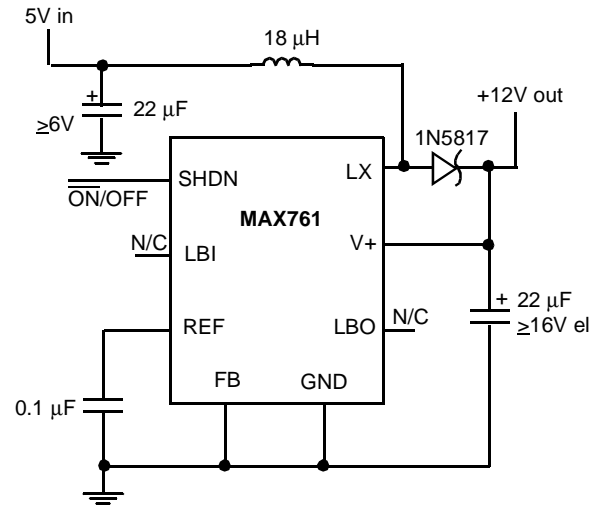
Figure 1. Linear Tech Schematic

Figure 2. Maxim Schematic
Table 2. Linear Tech Bill of Materials

Desig	Part #	Qty	Cost/100	Cost/10K
U1	LT1301	1	2.50	2.35
D1	1N5817	1	0.11	0.11
C1	100 µF 16V el	1	0.27	0.27
C2	47 µF 16V el	1	0.22	0.22
C3	0.1 µF cer	1	0.10	0.10
L1	22 µH ww	1	1.60	0.92
		6	4.80	3.97

Table 3. Maxim Bill of Materials

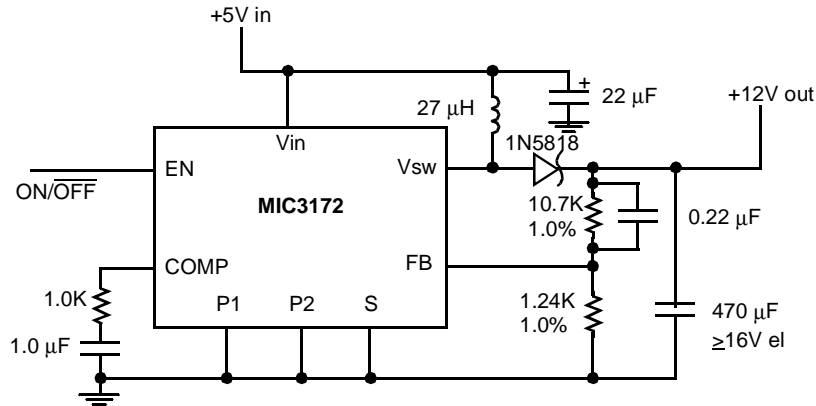
Desig	Part #	Qty	Cost/100	Cost/10K
U1	MAX761	1	2.41	2.20
D1	1N5817	1	0.11	0.11
C1	22 µF 16V el	2	0.44	0.44
C2	0.1 µF cer	1	0.10	0.10
L1	18 µH ww	1	1.60	0.92
		6	4.66	3.77

Figure 3. Micrel Schematic
Table 4. Micrel Bill of Materials

Desig	Part #	Qty	Cost/100	Cost/10K
U1	MIC3172	1	1.70	1.52
D1	1N5818	1	0.11	0.11
R1	10.7 KΩ 1%	1	0.02	0.02
R2	1.24 KΩ 1%	1	0.02	0.02
R3	1.0 KΩ	1	0.02	0.02
C1	22 μF 16V el	1	0.22	0.22
C2	470 μF 16V el	1	0.40	0.40
C3	1.0 μF cer	1	0.40	0.40
C4	0.22 μF	1	0.40	0.40
L1	27 μH ww	1	1.60	0.92
		10	4.89	4.03

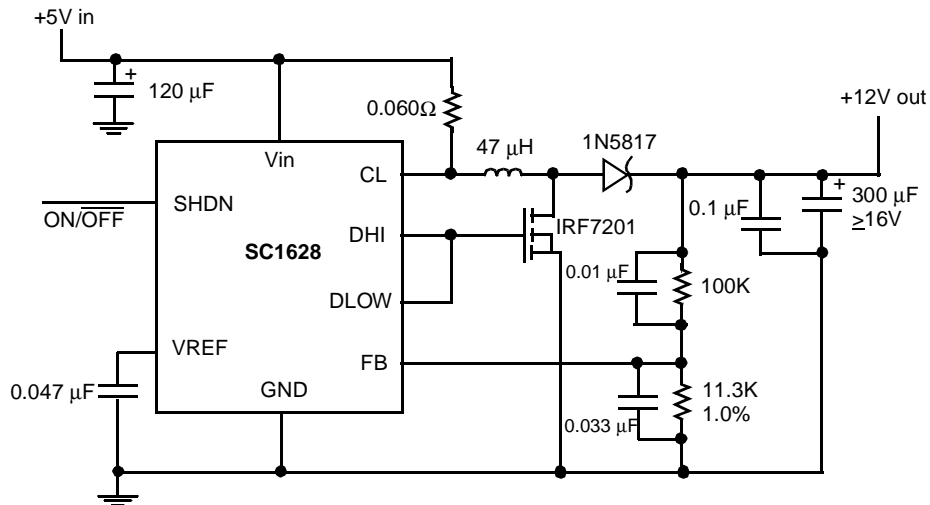

Figure 4. Semtech Schematic

Table 5. Semtech Bill of Materials

Desig	Part #	Qty	Cost/100	Cost/10K
U1	SC1628	1	2.17	1.71
Q1	IRF7201	1	1.72	1.42
D1	1N5817	1	0.11	0.11
R1	11.3KΩ 1%	1	0.02	0.02
R2	100KΩ	1	0.02	0.02
R3	0.060Ω *	1	1.70	1.20
C1	120 μF 16V el	1	0.27	0.27
C2	300 μF 16V el	1	0.33	0.33
C3	0.01 μF cer	1	0.40	0.40
C4	0.033 μF cer	1	0.40	0.40
C5	0.047 μF cer	1	0.40	0.40
C6	0.1 μF cer	1	0.40	0.40
L1	47 μH ww	1	1.60	0.92
		13	9.52	7.58

* Fuse suggested: MCR-2

Pricing

The prices provided are intended for “your-mileage-may-vary” comparisons. As you might expect, some manufacturers were reluctant to provide 10,000 piece prices to publish in this application note. Please check your local sources for current, accurate pricing. Pricing for passive components generally reflects quantity price breaks for a medium sized manufacturing company. These may not match your company’s costs, so, again, verify these with your Purchasing or Components department. SMT was used wherever possible.

Conclusions

Micrel’s and Semtech’s monolithic solutions are based on more generic parts which were intended for a wider variety of applications. Although the key components are less expensive, they require more additional components, and so were actually more expensive overall. But the qualified parts may be useful for a wide variety of other designs; this represents potential savings in inventory tracking and quantity purchasing.

Maxim and Linear Tech provide the best solutions overall since their monolithic approach was apparently designed for the flash programming niche. The key component is a little more expensive, but the complete circuit requires fewer additional components (board space and assembly time). Also, since MTBF calculations are loosely connected with part count, this implies better long term reliability estimates. All of the monolithic solutions use low profile components and would work well for height sensitive designs.

FLASH370i and ISR are trademarks of Cypress Semiconductor Corporation.